

TECHNICAL NOTE

NLY45LAa/b

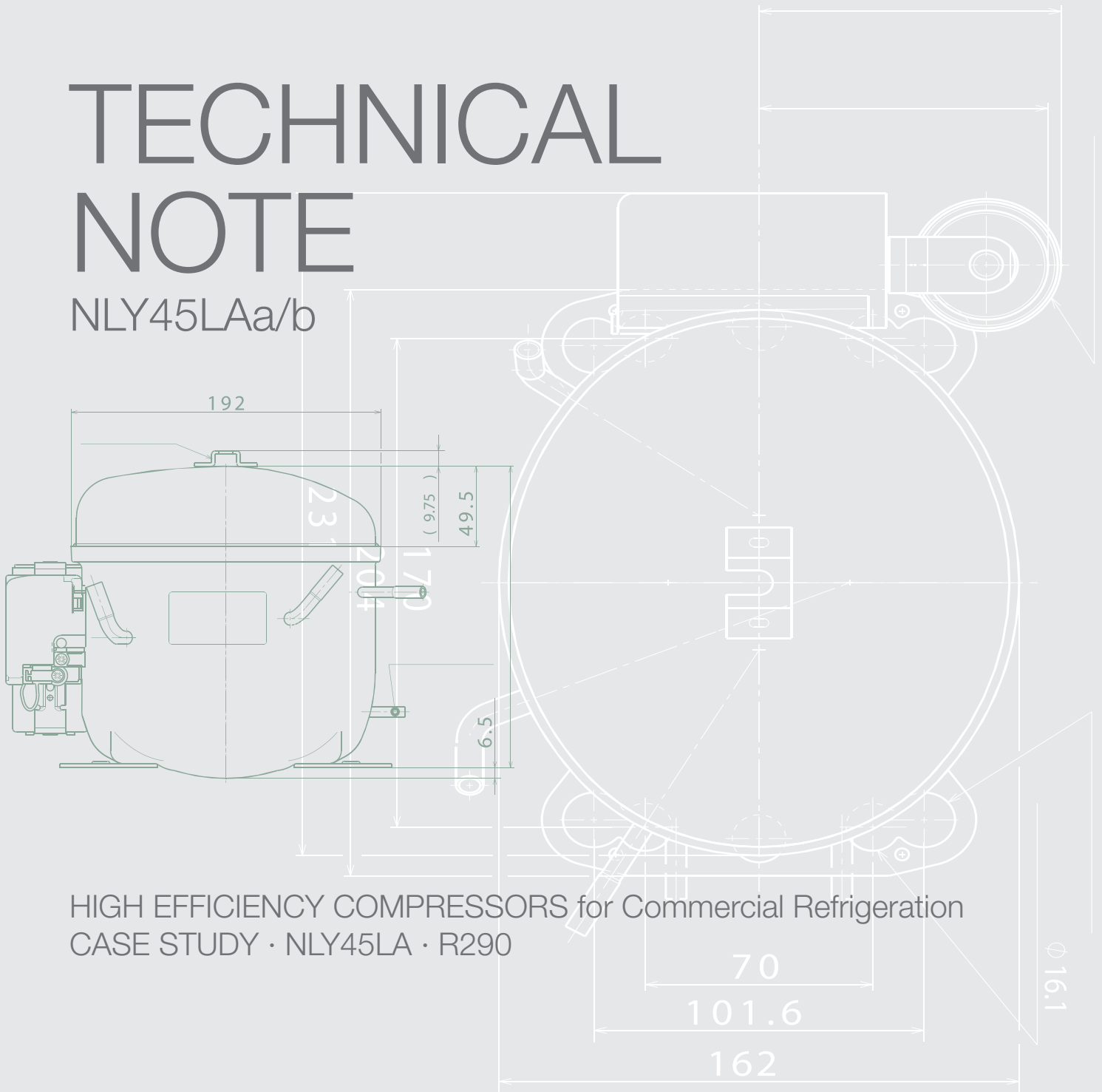

HIGH EFFICIENCY COMPRESSORS for Commercial Refrigeration
CASE STUDY · NLY45LA · R290



cubigel[®]
compressors

by
HUAYI
COMPRESSOR
BARCELONA

NLY45LAa/b:

High Efficiency Model with Natural Refrigerant



High Efficiency ranges have the most extended series working with R134a, R404A and natural refrigerants R290 and R600a for both, HMBP and LBP applications. These ranges get to improve the compressor COP between 15% and 30% while reducing energy consumption of commercial refrigeration appliances up to 25% with respect to standard compressors.

In parallel with high efficiency trend, market is moving towards the hydrocarbons (R290 and R600a) with the target of replacing the H-CFCs and HFCs refrigerants which have high impact on environment (like R134a or R404A).

In particular, the energy consumption of a R290 compressor is between 10% and 15% lower than a similar application with R404A. Additionally, propane has better dynamic behavior showing a lower increase of energy consumption with increasing ambient temperatures.

The major environmental benefits are obtained combining the use of the R290 with the design criteria of high efficiency range.

The combination of the use of R290 with high efficiency mechanical kit can save up to 50% in compressor energy consumption in a cabinet with a high efficiency R290 compressor if it is compared with a R404A standard efficiency compressor in the same cabinet.

NLY45LAa/b Main Advantages and Benefits

- Compressor power consumption reduction up to 50% in comparison to its equivalent R404A standard compressor.
- NLY45LA works with R290 which has no direct contribution to global warming (GWP = 3) and null Ozone Depletion Potential (ODP = 0).
- Advanced mechanical system design and improved refrigerant fluid dynamic performance.
- Advanced motor windings design and patented electrical diagram design which allows the “optional running capacitor” concept.
- Same compressor NLY45LA allows either CSIR (NLY45LAa) or CSR (NLY45LAb) versions only by means of changing the electrical components.
- Easy replacement in cabinet from its equivalent standard compressor.
- Wide working range: from -40°C to -10°C evaporating temperature range.
- Wide operating voltage range: from 187V to 264V at 50Hz.
- Compressor able to work up to 43°C ambient temperature.

Optional Running Capacitor Concept

Beside of the several important improvements in the mechanical kit, most High Efficiency models are equipped with electrical motors designed with the “optional running capacitor” concept. It means that same compressor can be CSIR or CSR depending on the electrical parts assembled. This patent-

ed system also allows having CSR versions (with starting and running capacitor) in the same compressor bracket (without the necessity of using a voltage relay together with its external bulky electrical box).

Comparison between ML45FB (R404A, standard efficiency) and NLY45LA (R290, high efficiency).

ML45FB @ -23,3/55°C				NLY45LA @ -23,3/55°C				
Model	Version	Capacity (kcal/h)	COP (W/W)	Model	Version	Capacity (kcal/h)	COP (W/W)	ΔCOP vs std
ML45FB	CSIR	170	0,94	NLY45LAa	CSIR	176	1,35	44%
				NLY45LAb	CSR	176	1,44	53%

NLY45LAa shows a COP increase of 44% for CSIR versions and a 53% increase for CSR version respect to same level of cooling capacity (about 170 kcal/h).



Appliance test: Ice cream conservator. ML45FB vs NLY45Lab

This real test in an ice cream conservator shows the benefits of using a high efficiency R290 compressor with running capacitor (NLY45Lab) in comparison with a R404A standard efficiency

compressor (ML45FB). The results are directly connected to the better efficiency of the R290 vs R404A and the high efficiency mechanics and electrical motor design.

Type of cabinet: Ice cream conservator

Application characteristics and test conditions	
Internal net volume	125 Liters
Cabinet load	Empty
Ambient temperature / RH	25°C / 50%
Average internal temperature	-18°C

Test and working conditions data		
	ML45FB	NLY45Lab
Compressor type	R404A std. effic.	R290 high effic.
Evaporating temperature	-32,3°C	-32,1°C
Condensing temperature	42,3°C	42,5°C
Duty cycle	52%	51%
Energy consumption	2,44 kWh/24h	1,61 kWh/24h
Energy consumption difference vs cabinet with NLY45Lab		34,0%

The result of the test shows 34% of energy saving when using R290 high efficiency model (NLY45La/b) equivalent to a R404A standard efficiency compressor (ML45FB).



NLY45Lab main technical characteristics	
Displacement:	4.56 cc
Gas:	R290
Application:	LBP (from -40°C to -10°C)
Power supply:	220-240V 50Hz
Compressor motor:	CSIR / CSR (for a and b version respectively)
Expansion system:	Capillary / Expansion Valve
Compressor cooling:	Fan
Max. ambient temp:	43°C
Protection:	Overload protector
Approvals:	VDE approved

NLY45LA compressor performances at ASHRAE conditions

Liquid temperature 32°C | Suction and return gas temperature 32°C | Ambient temperature 32°C

Cooling Capacity (kcal/h) in function of evaporating temperature

Cond. Temp.	-40°C	-35°C	-30°C	-23,3°C	-20°C	-15°C	-10°C
45°C	76	103	192	192	223	277	338
50°C	71	97	129	184	215	268	328
55°C	66	91	123	176	207	259	318
60°C	61	85	116	168	198	250	308

Input Power (W) in function of evaporating temperature

Cond. Temp.	-40°C		-35°C		-30°C		-23,3°C		-20°C		-15°C		-10°C	
	CSIR	CSR	CSIR	CSR	CSIR	CSR	CSIR	CSR	CSIR	CSR	CSIR	CSR	CSIR	CSR
45°C	102	96	111	107	120	120	134	137	141	146	153	160	165	175
50°C	100	96	112	108	125	121	143	139	152	149	167	164	182	180
55°C	98	95	113	108	129	122	152	142	163	152	181	168	200	185
60°C	96	95	115	109	134	124	161	145	174	155	196	172	218	190

C.O.P. (W/W) in function of evaporating temperature

Cond. Temp.	-40°C		-35°C		-30°C		-23,3°C		-20°C		-15°C		-10°C	
	CSIR	CSR	CSIR	CSR	CSIR	CSR	CSIR	CSR	CSIR	CSR	CSIR	CSR	CSIR	CSR
45°C	0.87	0.92	1.08	1.11	1.31	1.32	1.66	1.63	1.84	1.78	2.11	2.01	2.38	2.25
50°C	0.83	0.86	1.00	1.04	1.20	1.25	1.49	1.53	1.64	1.68	1.87	1.90	2.09	2.12
55°C	0.78	0.81	0.93	0.98	1.10	1.17	1.35	1.44	1.47	1.58	1.66	1.79	1.85	2.00
60°C	0.74	0.75	0.86	0.91	1.01	1.09	1.22	1.35	1.32	1.49	1.48	1.69	1.65	1.89

Current consumption (A) in function of evaporating temperature

Cond. Temp.	-40°C		-35°C		-30°C		-23,3°C		-20°C		-15°C		-10°C	
	CSIR	CSR	CSIR	CSR	CSIR	CSR	CSIR	CSR	CSIR	CSR	CSIR	CSR	CSIR	CSR
45°C	0.82	0.50	0.86	0.55	0.90	0.60	0.97	0.68	1.01	0.72	1.07	0.79	1.14	0.86
50°C	0.82	0.50	0.86	0.55	0.91	0.61	0.98	0.69	1.02	0.73	1.09	0.80	1.16	0.88
55°C	0.82	0.50	0.86	0.55	0.91	0.61	0.99	0.70	1.03	0.75	1.10	0.82	1.18	0.90
60°C	0.82	0.50	0.87	0.56	0.92	0.62	1.00	0.71	1.05	0.76	1.12	0.84	1.20	0.92

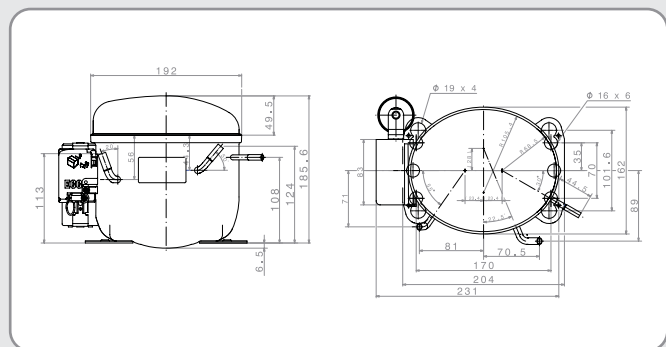

**HUAYI
COMPRESSOR
BARCELONA**

Huayi Compressor Barcelona, S.L.

Antoni Forrellad, 2 · 08192
Sant Quirze del Vallès · BCN · Spain
Phone: +34 93 710 60 08
Fax +34 93 710 69 58

www.huayicompressor.es